



Kenco Engineering, Inc.

TCI Products for Crushers

Does heavy crusher wear cause you maintenance headaches?



Cut your downtime & improve productivity



Horizontal Shaft Impactor:

- Achieve up to 5X or more wear life over OEM wear plates & apron liners
- Custom shapes & sizes available
- Offered for most makes & models
- Long wear life of apron liners reduces fines & increases productivity

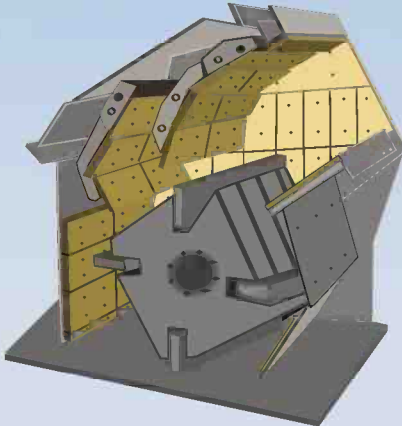

Jaw Crusher:

- Customers report up to 5X wear life over OEM cheek plates
- Available for most makes & models
- Custom shapes & sizes available
- No cheek plate too large or too small

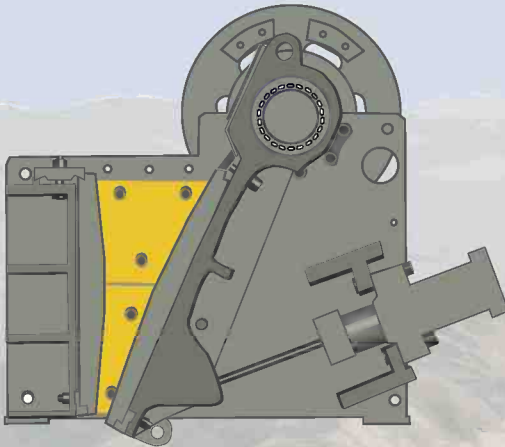

*Tungsten Carbide
Impregnated (TCI):



Whether you crush aggregate or recycle asphalt and concrete, Kenco can cut your maintenance costs. With Kenco's unique Tungsten Carbide Impregnation process, TC is embedded in the parent metal to a guaranteed depth of 1/4" -- no filler rod or wire used. This is true impregnation, not an overlay process!



Buckets:

- Kenco offers full protection for loader and excavator buckets
- From cutting edges to heel plates to moldboard protection-- you're covered!
- Cost-per-hour guarantee on all of our TCI cutting edges

Landing Zone Wear Plates:

- Wear on conveyor distribution plates or chutes? Kenco TC & Alloy K available to fit almost any shape & size
- Can come studded for easy installation & replacement

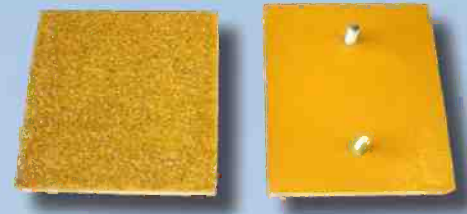

Kenco has many longer wearlife solutions for your plants and equipment using TCI, castings, and Wear Patch



Kenco Engineering, Inc.
P.O. Box 1467
Roseville, CA 95678
800-363-9859
www.kencoengineering.com

Distributed by:

